



cyla chair/ raised frame with castors datasheet

Extent of Range

Cyla is a versatile mesh back meeting and work chair with 3 base options, integral arms and black painted frame.



Delivery

This range is delivered pre-assembled by the Flexiform installation team, wrapped for protection.

Product Guarantee

10 years subject to T&C's. See the Flexiform Warranty document for more information.

Features

Type: Meeting & work chair

Back: One piece injection moulded polypropylene plastic with mesh supportive back. Black mesh and black fabric.

Seat: FSC timber and nylon core with Combustion Modified High Resilience (CMHR) foam. Waterfall seat for comfort.

Base: Raised base with 50mm non locking castors painted in black.

Arms: Plastic fixed twin arm in black.

Product Certification

EN 16139:2013 Test Level 1. Strength, durability and safety requirements for commercial seating.

Manufactured to ISO 9001, ISO 14001 & ISO 18001.

Product Environmental Certification



Environmental Data

Recycled Content: 25.29%

Recyclable Content: 94.49%

Dimensions

Overall Width: 720mm
Overall Depth: 720mm
Overall Height: 915mm
Seat Height: 465mm
Seat Width: 475mm
Seat Depth: 470mm
Back Width: 460mm
Overall Arm Height: 685mm
Arm Height from Seat: 210mm

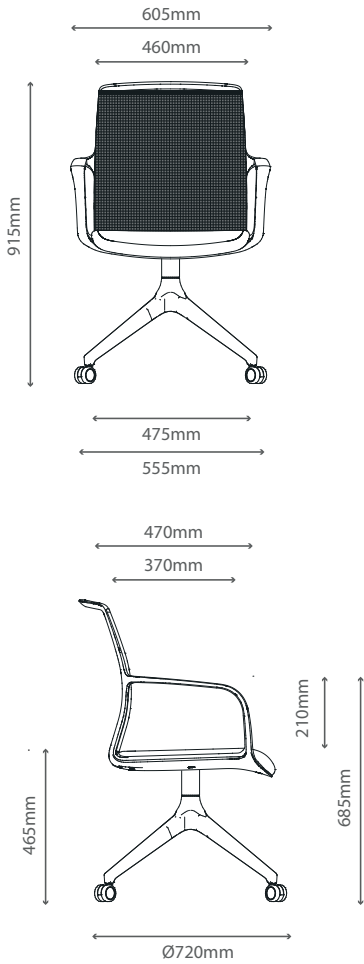

Materials

Polypropylene: Light weight plastic with ability to be moulded and shaped to an ergonomic seat. Tough material to withstand everyday use.

Seat Core: FSC timber and nylon core for strength.

Fabric Seat

Available in a range of fabric brands from group 1 – 5 & Leather from multiple fabric manufacturers.

Mesh Finishes

Standard Flexiform finishes.



Only available in Black

Frame, Arms & Base

Standard Flexiform finishes.



Only available in Black